



TEMPLATES

Make a string puppet

Making this puppet will certainly test your skills but when it is completed you will have hours of fun with your new friend.

The instructions are in two stages. In stage one you will make the puppet and in stage two you will dress it and make it move.

Everything you will need for both stages is listed below and the instructions are on pages 2 to 6.

Please note: Adult supervision is recommended for this activity.

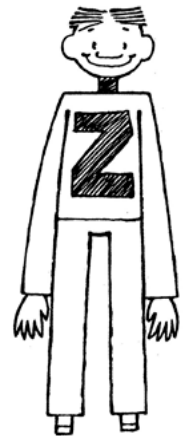

What you will need (per puppet)

Stage 1:

- Old newspapers. Tear some pages into strips and leave some pages whole.
- Five lengths of old material, measuring 27cm x 1cm
- Paint and brush for painting the face
- Ruler
- Paper glue (as used for papier mache)
- Sheet of plastic to protect your working surface
- 23 paddle pop sticks
- 50 strands of 8 ply wool, each about 15cm long
- Scissors
- PVA glue
- 1 small sheet of thick cardboard

Stage 2:

- Your string puppet (stage one completed)
- 10 tiny screw eyes
- 3 lengths of fine nylon line, 40cm long
- 4 lengths of nylon line, 60cm long
- 4 pieces of matchstick or toothpick, about 1cm long
- 11 paddle pop sticks
- 2 clothes pegs
- 2 pieces of material approx. 40cm x 20cm
- 2 pieces of material approx. 60cm x 20cm
- Sheet of plastic to cover your work surface
- Sewing scissors
- A few pins
- Sewing machine
- PVA glue
- Needle and cotton
- A sheet of paper for the clothes pattern
- ½ metre of thin lace (optional)
- Tape



TEMPLATES

Stage 1 Instructions

The head:

1. Take a small sheet of newspaper (about A4 size) and screw it up tightly to form the beginning of the head.
2. Take one strip of material and tuck it into the centre of the ball. Make sure approximately 18cm of material is hanging from the head as shown in Fig 1.
3. Use the paper glue to paste strips of newspaper around the head (papier mache style) until it is slightly larger than a golf ball. You can mould the head into any shape you like.
4. Leave the head aside to dry completely.

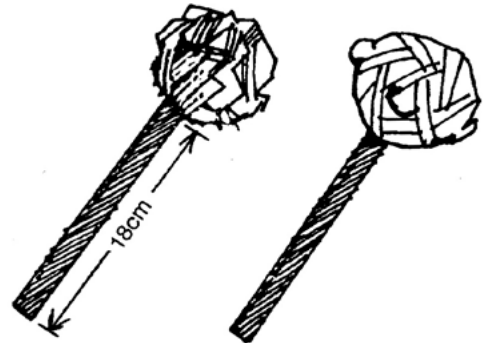

Fig 1

The body:

1. Cut out two hand templates (there are choices on the last page). Trace these onto cardboard, cut them out and leave to one side.
2. When the head is dry, lay it on the sheet of plastic with the other pieces of material set in position as shown in Fig 2.
3. Now lay 11 of the paddle pop sticks on the material as shown in Fig 3., making sure there is a 1cm space between the ends of the sticks and 2 cm between the head and the shoulder joint.
4. Run some PVA glue along one stick at a time and glue into position on the material. (Use only enough glue to ensure the paddle pop sticks are stuck securely.)
5. Leave your puppet to dry for about 1 hour.

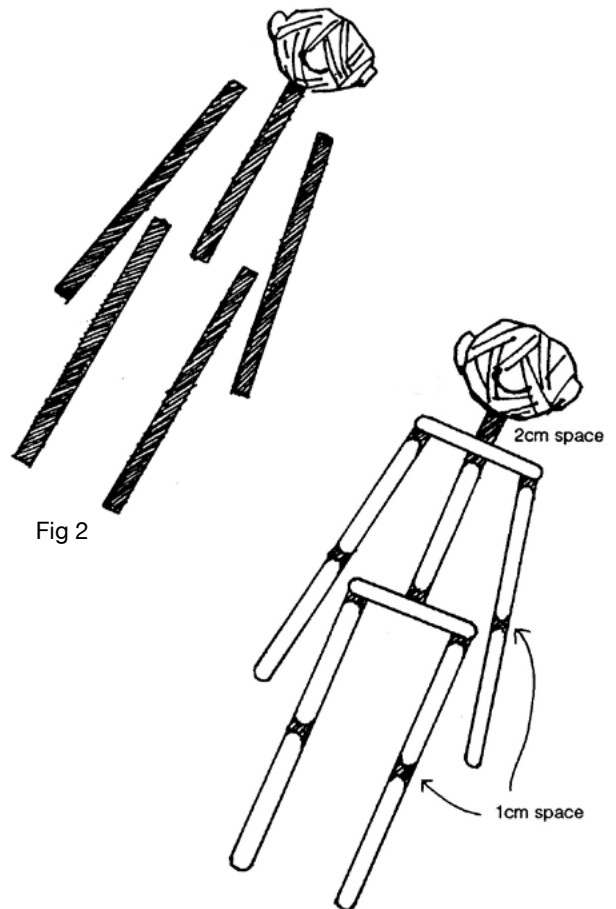

Fig 2

Fig 3



TEMPLATES

- When dry, carefully turn your puppet over and glue another 11 paddle pop sticks in the same positions as those on the other side of the material. Make sure you glue the hands in between the two paddle pop sticks (as shown in Fig. 4).
- Leave your puppet to dry again.

The feet:

- Take the remaining paddle pop stick. Lay it flat. Measure 3cm in from each end and get an adult to cut the feet out for you as shown in Fig 5.
- Lay your puppet flat on its back on your sheet of plastic. Put a very small amount of PVA glue on the heel end of the foot and lean the foot up against the leg as shown in Fig 6.
- Leave in that position to dry thoroughly.

The face:

- Let your imagination run wild and paint the face of your puppet.

The hair:

- Take one strand of wool and lay it on your plastic sheet. Run some PVA glue along the strand marked A-B on Fig 7.
- Then lay the other strands close together across the one with the glue on it as shown. Leave your puppet's hair to dry.
- Repeat steps 2 and 3 to make another hair piece.

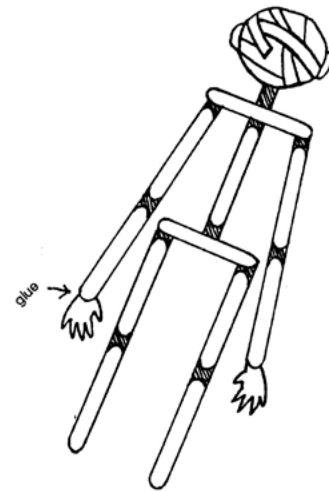

Fig 4

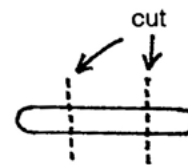

Fig 5

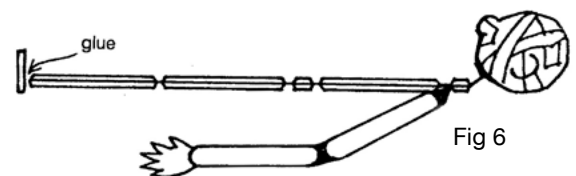

Fig 6

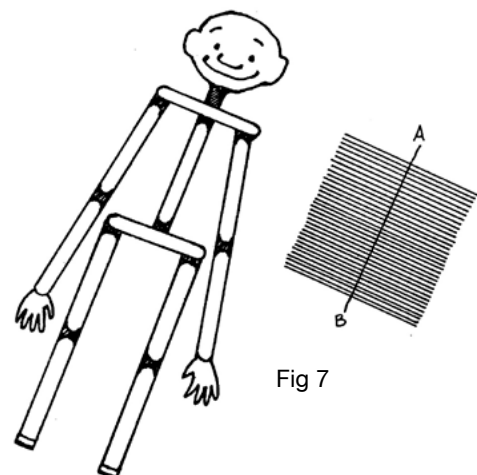

Fig 7



TEMPLATES

- When dry, carefully peel the hair off the plastic. Run a bead of PVA glue over the top of the puppet's head from front to back and lay the hair on top. Make sure you glue both pieces onto the head as shown in Fig. 8.
- Allow to dry and then trim up the hair with the scissors. (Be careful not to get too carried away, or you could end up with a bald puppet again.)



Fig 8

Stage 1 of your puppet is now complete.

Stage 2 instructions

Now it's time to dress your puppet and make it move.

The shirt:

- On a piece of paper, use the measurements shown on Fig. 9 as a guide to draw a pattern for your puppet's shirt. Cut this out.
- Select the piece of material you want to use for the shirt and fold it in half.
- Lay the pattern on top of your folded material and pin securely.
- Cut around the pattern, making sure that you cut completely through the material. You should now have a front and back piece for your shirt.
- Sew the back and front together leaving the 6cm sleeve ends, the 19cm bottom end and part of the top section open (this will allow the puppet's head to go through the shirt).
- Put the shirt over your puppet's head and carefully thread its arms through the sleeves.
- Put some glue along the neck piece to seal it.

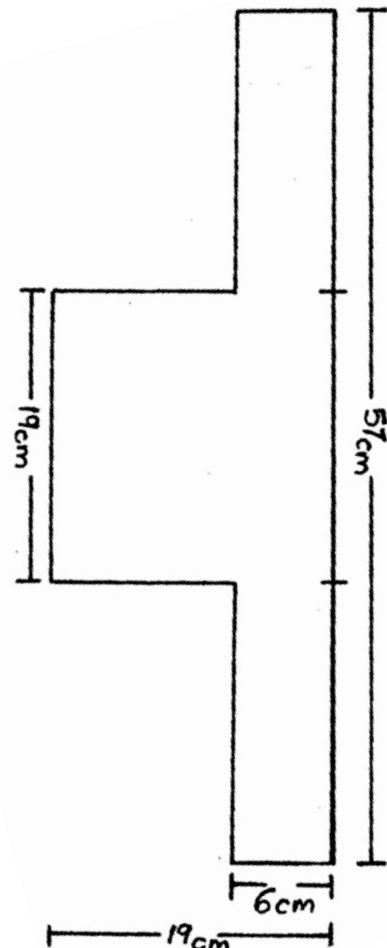

Fig 9



TEMPLATES

The pants:

1. Make a pattern for the pants as for the shirt using measurements in Fig. 10.
2. Cut out and sew the same way as with the shirt, leaving the 15cm and 6cm ends open.
3. Dress your puppet and sew a 'gathering stitch' around the top of the pants, the bottom of the shin and the wrists and ankles. (Stitch the tiny piece of lace around the wrists and the ankles if you like.)

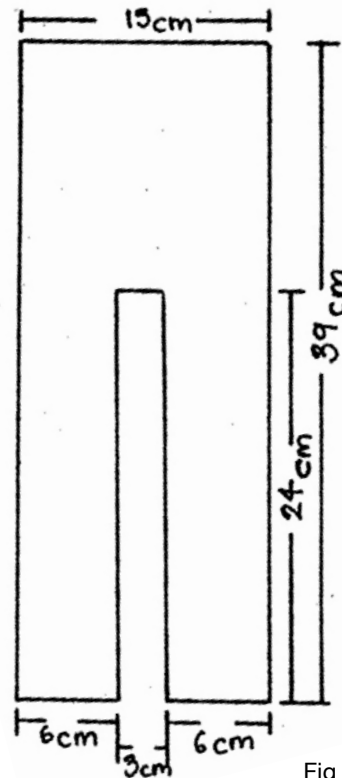

Fig 10

The H hanger:

1. Lay six paddle pop sticks (numbered 1 to 6) on your sheet of plastic to form the letter H as shown in Fig. 11.
2. Take another three paddle pop sticks (7, 8 and 9). One at a time, put some glue down each stick and place them on top of the others as shown in Fig. 11.
3. When the glue is set turn the H over and glue 3 more sticks opposite 7, 8 and 9 and allow to dry.
4. Take four screw eyes and screw them into the H hanger, in the positions marked with an X on Fig 11.
5. Tie 4 pieces of 60cm nylon on to the eyes.

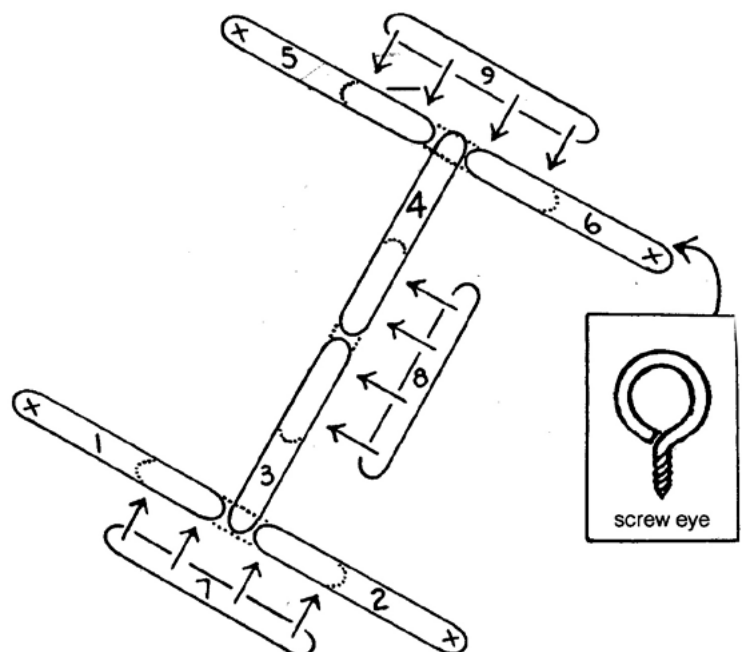

Fig 11



TEMPLATES

The T hanger:

1. Glue 3 paddle pop sticks into a T shape as shown in Fig. 12, making sure stick number 1 is glued in between sticks 2 and 3.
2. Hold together with clothes pegs until the glue is set.
3. When dry, remove pegs and screw in screw eyes where shown.
4. Then tie the 40cm lengths of nylon to each eye.

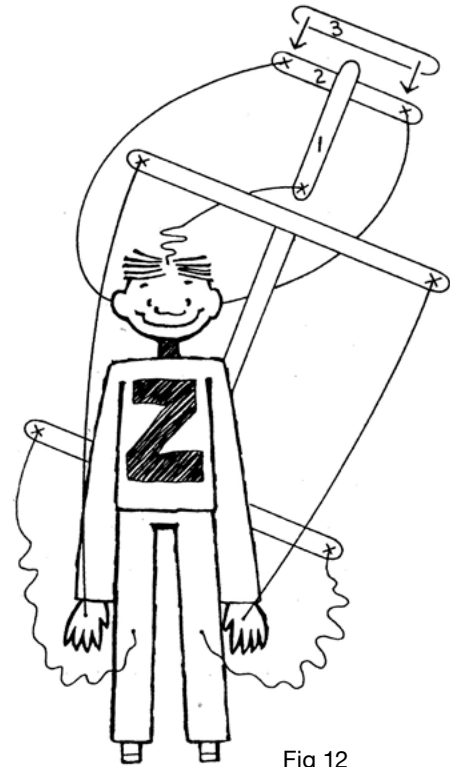
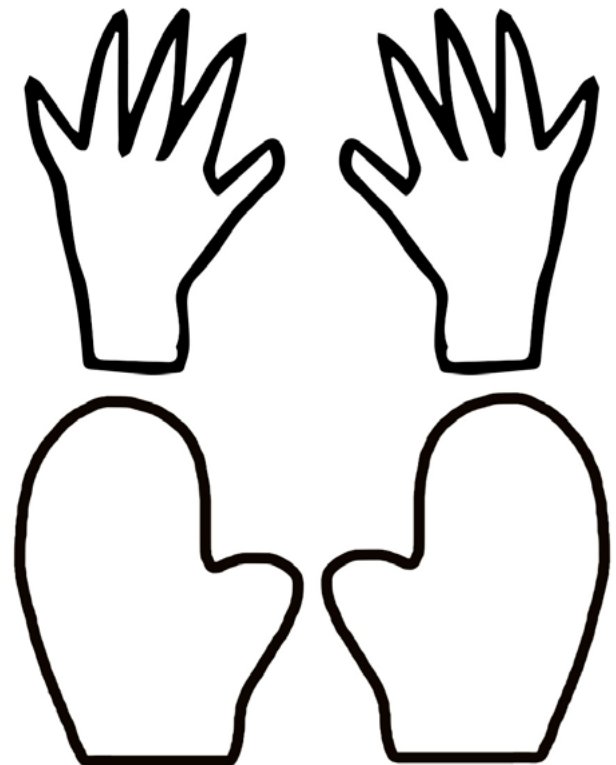

Fig 12

The finishing touches

1. Screw three screw eyes into the head of your puppet in the positions shown in in Fig 12.
2. Tie the loose ends of the nylon attached to the T hanger to the screw eyes in the puppet's head. The T hanger is then used to move the puppet's head.
3. Make sure your puppet is fully dressed, then, one at a time, thread the loose ends of the nylon attached to the H hanger through a needle and sew through the puppet's knees and hands as shown in Fig 12.
4. Tie a 1cm piece of matchstick/toothpick to the end of the nylon which has been threaded through the knees and hands. You may need to get an adult to cut a little groove around the centre of the matchstick to keep the nylon from slipping off the stick. Alternately, you could use some tape to secure the nylon to the knees and hands.
5. The H hanger can be used to move your puppet's arms and legs.



Your puppet is now complete and you can make it move however you wish.